

LOT LINE CONSOLIDATION
 LLC NO. SUB22-001
 CITY OF MERCER ISLAND, WASHINGTON

DEDICATION

WE, THE UNDERSIGNED, OWNER(S) IN FEE SIMPLE OF THE LAND HEREIN DESCRIBED DO HEREBY MAKE A LOT LINE CONSOLIDATION THEREOF PURSUANT TO RCW 58.17.040 AND DECLARE THAT THIS LOT LINE CONSOLIDATION TO BE THE GRAPHIC REPRESENTATION OF SAME, AND THAT SAID LOT LINE CONSOLIDATION IS MADE WITH THE FREE CONSENT AND IN ACCORDANCE WITH THE DESIRES OF THE OWNERS. IN WITNESS WHEREOF WE HAVE SET OUR HANDS AND SEALS.

XING HUA GROUP LTD., A WASHINGTON CORPORATION

BY: TINA LU DATE
 ITS: SECRETARY/TREASURER

STATE OF WASHINGTON)
) SS
 COUNTY OF KING)

I CERTIFY THAT I KNOW OR HAVE SATISFACTORY EVIDENCE THAT TINA LU IS THE PERSON THAT APPEARED BEFORE ME AND SAID PERSON ACKNOWLEDGED THAT SHE SIGNED THIS INSTRUMENT; ON OATH STATED THAT SHE WAS AUTHORIZED TO EXECUTE THE INSTRUMENT; AND ACKNOWLEDGED IT AS THE SECRETARY/TREASURER OF XING HUA GROUP LTD., TO BE THE FREE AND VOLUNTARY ACT OF SUCH PARTY FOR THE USES AND PURPOSES MENTIONED IN THE INSTRUMENT.

PRINT NAME: _____
 NOTARY PUBLIC IN AND FOR THE STATE OF WASHINGTON
 RESIDING AT _____
 COMMISSION EXPIRES _____

APPROVALS
 DEPARTMENT OF ASSESSMENTS
 EXAMINED AND APPROVED THIS ____ DAY OF _____, 20____
 ASSESSOR _____ DEPUTY ASSESSOR _____
 TAX PARCEL NO's.: 531510-1326 & 531510-1316

APPROVALS
 CITY OF MERCER ISLAND
 REVIEWED AND APPROVED THIS ____ DAY OF _____, 20____
 CODE OFFICIAL _____

APPROVALS
 CITY OF MERCER ISLAND
 REVIEWED AND APPROVED THIS ____ DAY OF _____, 20____
 CITY ENGINEER _____

RECORDING NO. _____ VOL./PG. _____

EXISTING LEGAL DESCRIPTIONS:
 PARCEL 1
 PARCEL 1 OF MERCER ISLAND SHORT PLAT NUMBER 77-9-040, RECORDED OCTOBER 25, 1977 UNDER RECORDING NUMBER 7710250620, IN KING COUNTY, WASHINGTON.
 PARCEL 2
 PARCEL 2 OF MERCER ISLAND SHORT PLAT NUMBER 77-9-040, RECORDED OCTOBER 25, 1977 UNDER RECORDING NUMBER 7710250620, IN KING COUNTY, WASHINGTON.
NEW LEGAL DESCRIPTION:
 LOT A
 PARCELS 1 AND 2 OF MERCER ISLAND SHORT PLAT NUMBER 77-9-040, RECORDED OCTOBER 25, 1977 UNDER RECORDING NUMBER 7710250620, IN KING COUNTY, WASHINGTON.
 TITLE REPORT REFERENCE:
 THIS SURVEY WAS CONDUCTED ACCORDING TO THE DESCRIPTION SHOWN, FURNISHED BY FIDELITY NATIONAL TITLE INSURANCE COMPANY, SUBDIVISION GUARANTEE NO. 23000683-SC, DATED MAY 5, 2023. THE EASEMENTS SHOWN OR NOTED HEREON RELATE TO THIS COMMITMENT.
 NO.: EASEMENTS CREATED OR RESCINDED AFTER THIS DATE ARE NOT SHOWN OR NOTED HEREON.
EASEMENTS:
 1. RIGHT TO MAKE NECESSARY SLOPES FOR CUTS OR FILLS UPON PROPERTY HEREIN DESCRIBED AS GRANTED OR RESERVED IN DEED: IN FAVOR OF: KING COUNTY
 RECORDING DATE: OCTOBER 17, 1958
 RECORDING NO.: 4955634
 AFFECTS: PARCEL 2
 2. EASEMENT(S) FOR THE PURPOSE(S) SHOWN BELOW AND RIGHTS INCIDENTAL THERETO, AS GRANTED IN A DOCUMENT:
 GRANTED TO: PUGET SOUND POWER AND LIGHT COMPANY
 PURPOSE: ELECTRIC TRANSMISSION AND/OR DISTRIBUTION LINE, TOGETHER WITH NECESSARY APPURTENANCES
 RECORDING DATE: FEBRUARY 1, 1974
 RECORDING NO.: 7402010401
 AFFECTS: PORTION OF PARCEL 1
 3. COVENANTS, CONDITIONS, RESTRICTIONS, RECITALS, RESERVATIONS, EASEMENTS, EASEMENT PROVISIONS, ENCROACHMENTS, DEDICATIONS, BUILDING SETBACK LINES, NOTES, STATEMENTS, AND OTHER MATTERS, IF ANY, BUT OMITTING ANY COVENANTS OR RESTRICTIONS, IF ANY, INCLUDING BUT NOT LIMITED TO THOSE BASED UPON RACE, COLOR, RELIGION, SEX, SEXUAL ORIENTATION, FAMILIAL STATUS, MARITAL STATUS, DISABILITY, HANDICAP, NATIONAL ORIGIN, ANCESTRY, OR SOURCE OF INCOME, AS SET FORTH IN APPLICABLE STATE OR FEDERAL LAWS, EXCEPT TO THE EXTENT THAT SAID COVENANT OR RESTRICTION IS PERMITTED BY APPLICABLE LAW, AS SET FORTH ON SHORT PLAT NO. MI-77-9-040: RECORDING NO:
 4. EASEMENT(S) FOR THE PURPOSE(S) SHOWN BELOW AND RIGHTS INCIDENTAL THERETO, AS GRANTED IN A DOCUMENT:
 GRANTED TO: PUGET SOUND POWER AND LIGHT COMPANY
 PURPOSE: ELECTRIC TRANSMISSION AND/OR DISTRIBUTION LINE, TOGETHER WITH NECESSARY APPURTENANCES
 RECORDING DATE: DECEMBER 28, 1977
 RECORDING NO.: 7712280706
 AFFECTS: PORTION OF PARCEL 2
 AMENDED BY INSTRUMENT(S): PARTIAL RELEASE OF EASEMENT
 RECORDING DATE: MAY 25, 1995
 RECORDING NO.: 9505250194
 5. EASEMENT(S) FOR THE PURPOSE(S) SHOWN BELOW AND RIGHTS INCIDENTAL THERETO, AS GRANTED IN A DOCUMENT:
 GRANTED TO: CITY OF MERCER ISLAND
 PURPOSE: PLANTING AND LANDSCAPING
 RECORDING DATE: JANUARY 22, 1982
 RECORDING NO.: 8201220491
 AFFECTS: PORTION OF PARCEL 1
 6. EASEMENT(S) FOR THE PURPOSE(S) SHOWN BELOW AND RIGHTS INCIDENTAL THERETO, AS GRANTED IN A DOCUMENT:
 GRANTED TO: CITY OF MERCER ISLAND
 PURPOSE: PUBLIC UTILITIES
 RECORDING DATE: NOVEMBER 22, 1994
 RECORDING NO.: 9411221152
 AFFECTS: PORTION OF PARCEL 2

7. EASEMENT(S) FOR THE PURPOSE(S) SHOWN BELOW AND RIGHTS INCIDENTAL THERETO, AS GRANTED IN A DOCUMENT:
 GRANTED TO: CITY OF MERCER ISLAND
 PURPOSE: SIDEWALK
 RECORDING DATE: NOVEMBER 22, 1994
 RECORDING NO.: 9411221154
 AFFECTS: PORTION OF PARCEL 1

8. EASEMENT(S) FOR THE PURPOSE(S) SHOWN BELOW AND RIGHTS INCIDENTAL THERETO, AS GRANTED IN A DOCUMENT:
 GRANTED TO: CITY OF MERCER ISLAND
 PURPOSE: PUBLIC SIDEWALK
 RECORDING DATE: SEPTEMBER 2, 2005
 RECORDING NO.: 20050902001543
 AFFECTS: PORTION OF PARCEL 1

DESIGNATED BUILDING PAD:
 THIS SITE HAS NO MINIMUM SETBACKS, THEREFORE THE DESIGNATED BUILDING PAD IS THE ENTIRE SITE.

NOTES:
HORIZONTAL DATUM:
 NAD 83/2011 EPOCH 2010.00

BASIS OF POSITION:
 FOUND MONUMENT IN CASE AT THE INTERSECTION OF THE CENTERLINES OF RIGHT-OF-WAY OF SE 29TH STREET AND 78TH AVENUE SE. SAID MONUMENT IS A 1.5 INCH BRASS DISC, WITH A PUNCH MARK, IN A CONCRETE POST, 0.9 FEET BELOW GRADE, VISITED IN SEPTEMBER, 2013.

BASIS OF BEARING:
 CENTERLINE OF RIGHT-OF-WAY OF SE 29TH STREET BETWEEN THE ABOVE REFERENCED BASIS OF POSITION MONUMENT AND A FOUND MONUMENT IN CASE LOCATED AT THE INTERSECTION OF THE CENTERLINES OF RIGHT-OF-WAY OF SE 29TH STREET AND 77TH AVENUE SE.
 BEARING = NORTH 88°30'53" WEST

BOUNDARY:
REFERENCES:
 -MERCER ISLAND SHORT PLAT NO. 77-9-040 PER KING COUNTY RECORDING NO. 7710250620.
 -PLAT OF MCGILVRA'S ISLAND ADDITION, ACCORDING TO THE PLAT RECORDED IN VOLUME 16 OF PLATS, PAGE 58, RECORDS OF KING COUNTY, WASHINGTON.
 -CITY OF MERCER ISLAND SURVEY CONTROL MONUMENTS 9110, 8659, 9005 AND 7988 ESTABLISHED IN APRIL, 2002 AND POSTED IN THE WGS SURVEY DATA WAREHOUSE.

FIELDWORK:
 ORIGINAL BOUNDARY CONTROL AND TOPOGRAPHIC SURVEY FOR THIS SITE DONE IN SEPTEMBER, 2013 WITH ADDITIONAL FIELDWORK DONE IN NOVEMBER, 2018. FIELDWORK WAS PERFORMED WITH A LEICA TCR 1203 TOTAL STATION, SERIAL NUMBER 228553, MAINTAINED TO MANUFACTURER'S SPECIFICATIONS AS REQUIRED BY WAC-332-130-100. SURVEY PRECISION MEETS OR EXCEEDS GUIDELINES AS DEFINED BY WASHINGTON STATE STANDARDS AS SHOWN UNDER WAC-332-130-090.

ENVIRONMENTALLY CRITICAL AREAS:
 ACCORDING TO KING COUNTY (PER "1-MAP") THERE IS A SLIVER OF LAND APPROXIMATELY 1,700 SQUARE FEET IN SIZE ALONG THE WEST BOUNDARY, ADJACENT TO 77TH AVENUE SE, THAT IS SHOWN AS BEING IN AN EROSION HAZARD ZONE. VIRTUALLY THE ENTIRETY OF THIS AREA LIES WITHIN THE FOOTPRINT OF A BUILDING AND IS SURROUNDED BY PAVED STREET, SIDEWALK AND DRIVEWAY AREAS.

APPROVAL NOTE:
 THIS LOT LINE REVISION REQUEST QUALIFIES FOR EXEMPTION UNDER RCW 58.17.040. IT DOES NOT GUARANTEE THE LOTS WILL BE SUITABLE FOR DEVELOPMENT NOW OR IN THE FUTURE. THE LEGAL TRANSFER OF THE PROPERTY MUST BE DONE BY SEPARATE INSTRUMENT UNLESS ALL LOTS HEREIN ARE UNDER THE SAME OWNERSHIP.

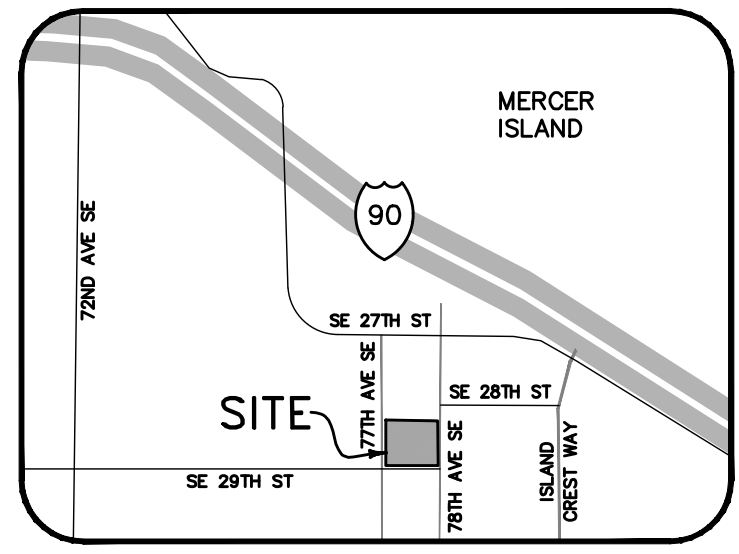

VICINITY MAP
 NO SCALE

RECORDER'S CERTIFICATE
 FILED FOR RECORD THIS ____ DAY OF _____, 20____ AT _____ M IN BOOK _____ OF SURVEYS, AT PAGE _____ AT THE REQUEST OF BUSH, ROED & HITCHINGS, INC.
 _____ MANAGER _____ SUPT. OF RECORDS

SURVEYOR'S CERTIFICATE
 THIS MAP CORRECTLY REPRESENTS A SURVEY MADE BY ME OR UNDER MY DIRECTION IN CONFORMANCE WITH THE REQUIREMENTS OF THE SURVEY RECORDING ACT AT THE REQUEST OF XING HUA GROUP LTD
 IN NOVEMBER, 2022.
 DAKIN A. BELL, PLS# 37546



BUSH, ROED & HITCHINGS, INC.
 LAND SURVEYORS & CIVIL ENGINEERS
 15400 SE 30TH PL, SUITE 100 (206) 323-4144
 BELLEVUE, WASHINGTON 1-800-935-0508
 98007 FAX# (206) 323-7135

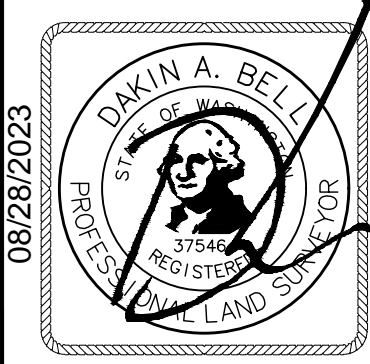

SW 1/4, NE 1/4,
 SEC 12, TWP 24 N, RGE 4 E, W.M.
 DWN. BY: LMK SCALE: 1"=30'
 CHK. BY: DAB JOB NO.: 2013130-08
 DATE: 8/28/23 SHEET 1 OF 3

EXISTING CONDITIONS

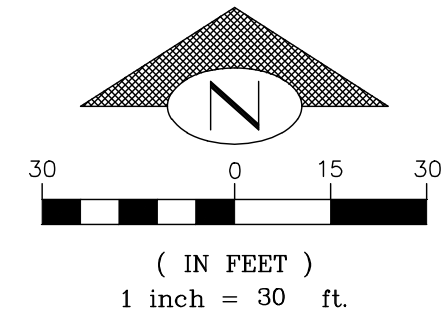
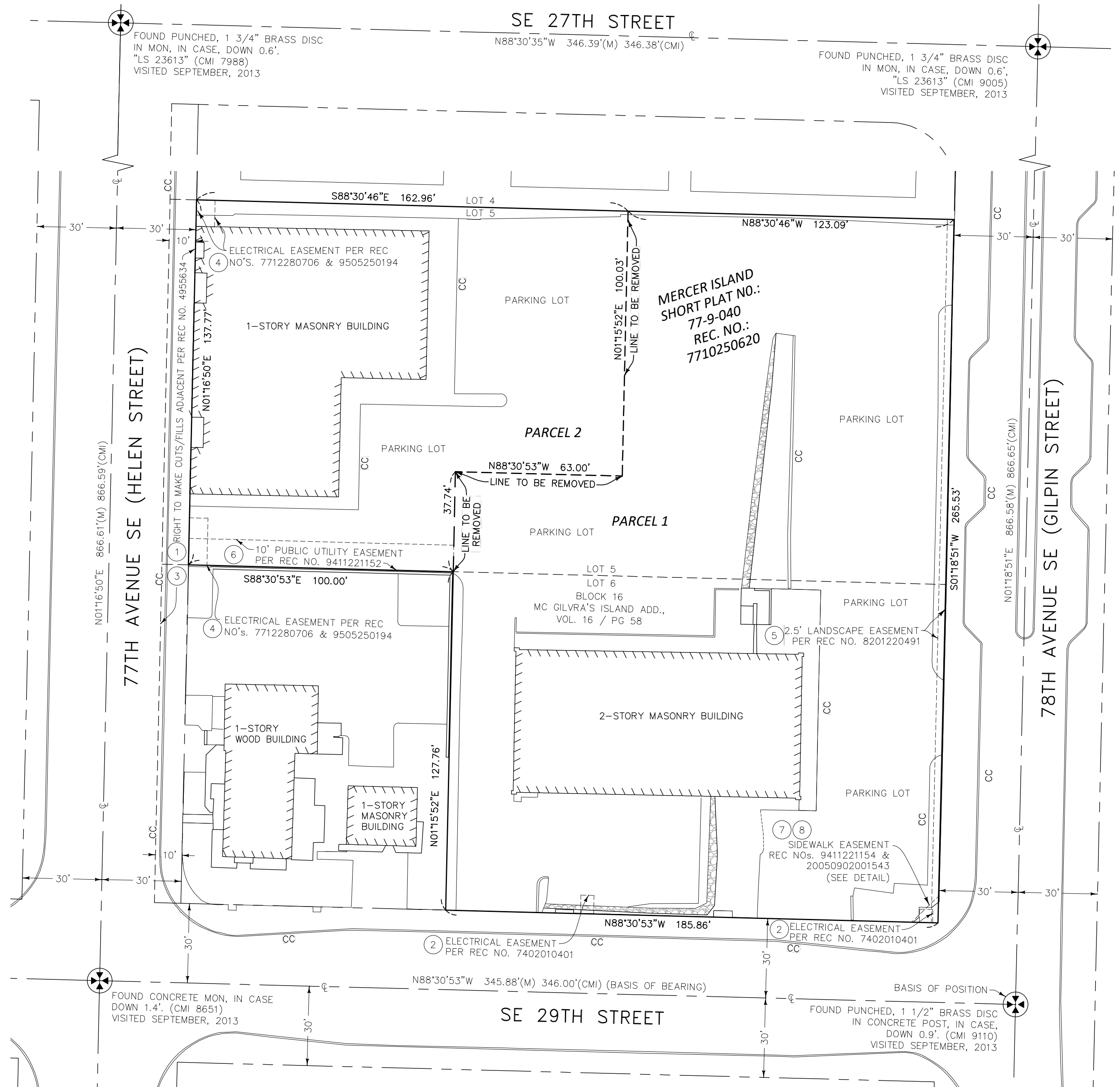

EASEMENTS				
TYPE	RECORDING NO.	PUBLIC/PRIVATE	GRANTOR	GRANTEE
ELECTRICAL	7402010401	PRIVATE	GARFIELD A. ALM & KATHLEEN H. ALM	PUGET SOUND POWER & LIGHT COMPANY
LANDSCAPE	8201220491	PUBLIC	GARFIELD A. ALM	CITY OF MERCER ISLAND
ELECTRICAL	7712280706 9505250194	PRIVATE	PIZZA HUT OF SPOKANE	PUGET SOUND POWER & LIGHT COMPANY
UTILITIES	9411221152	PUBLIC	2800 ASSOCIATES	CITY OF MERCER ISLAND
SIDEWALK	20050902001543 9411221154 (9411221154 HAS A BAD LEGAL DESCRIPTION)	PUBLIC	DAVID E. KING & JUDITH M. KING	CITY OF MERCER ISLAND

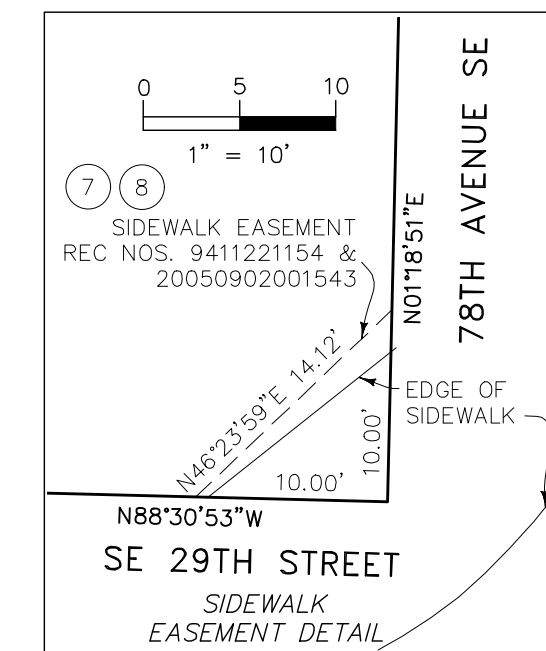

- LEGEND
- BUILDING LINE
 - ⊕ CENTERLINE
 - (CMI) CITY OF MERCER ISLAND
 - CC CONCRETE CURB
 - (M) MEASURED
 - ⊗ MONUMENT IN CASE
 - REC RECORDING
 - ⚡ ROCKERY

AREA TABLE		
PARCEL/LOT	SQUARE FEET	ACRES
EXISTING PARCEL 1	43,079	0.9890
EXISTING PARCEL 2	20,076	0.4609
LOT A (NEW)	63,155	1.4499

BUSH, ROED & HITCHINGS, INC.
 LAND SURVEYORS & CIVIL ENGINEERS

15400 SE 30TH PL, SUITE 100 (206) 323-4144
 BELLEVUE, WASHINGTON 1-800-935-0508
 98007 FAX# (206) 323-7135

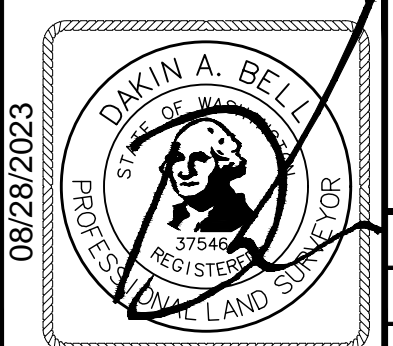

SW 1/4, NE 1/4,
 SEC 12, TWP 24 N, RGE 4 E, W.M.

DWN. BY: LMK	SCALE: 1"=30'
CHK. BY: DAB	JOB NO.: 2013130.08
DATE: 8/28/23	SHEET 2 OF 3

PROPOSED PARCEL

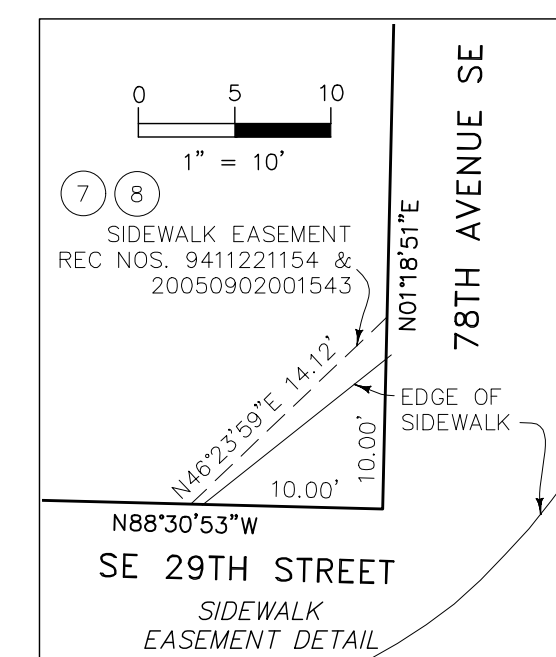
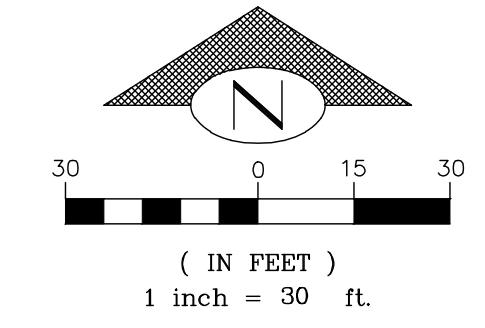
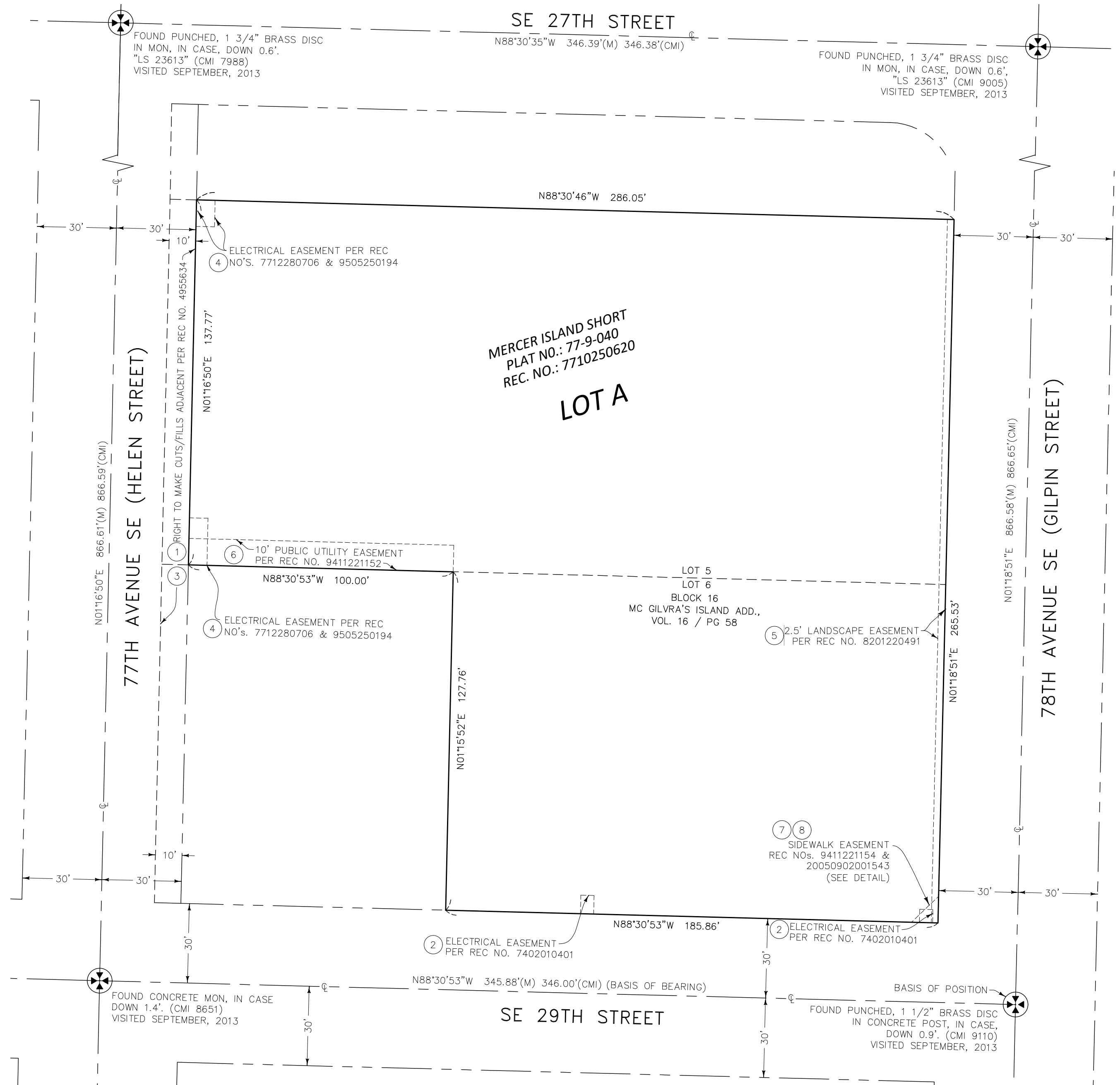

BUSH, ROED & HITCHINGS, INC.
 LAND SURVEYORS & CIVIL ENGINEERS

15400 SE 30TH PL, SUITE 100 (206) 323-4144
 BELLEVUE, WASHINGTON 1-800-935-0508
 98007 FAX# (206) 323-7135



SW 1/4, NE 1/4,
 SEC 12, TWP 24 N, RGE 4 E, W.M.

DWN. BY: LMK	SCALE: 1"=30'
CHK. BY: DAB	JOB NO.: 2013130.08
DATE: 8/28/23	SHEET 3 OF 3